

Nesea
Palmanova



aedashomes.com

Editing and design: AEDAS Homes

Dossier: The images shown are closest possible portrayal of the final result of the planned property, although there may be modifications derived from technical or legal requirements, provided they are justified and do not represent a material alteration of the object and/or quality of the materials. The furniture shown is not included and the fittings included with the property are as indicated in the building specifications. All information provided and documentation supplied will be compliant with Royal Decree 515/1989, of 21 April, and any other supplementary rules, be they of a state or regional nature.

Building Specifications: The images shown are the closest possible portrayal of the final result of the planned property with the specifications indicated in this document, although there may be modifications derived from technical or legal requirements, provided they are justified and do not represent a material alteration of the object and/or a lessening of the quality of the materials/fittings of the property. The furniture shown is not included. All information provided and documentation supplied will be compliant with Royal Decree 515/1989, of the 21 April, and any other supplementary rules, be they of a state or regional nature.

© 2024

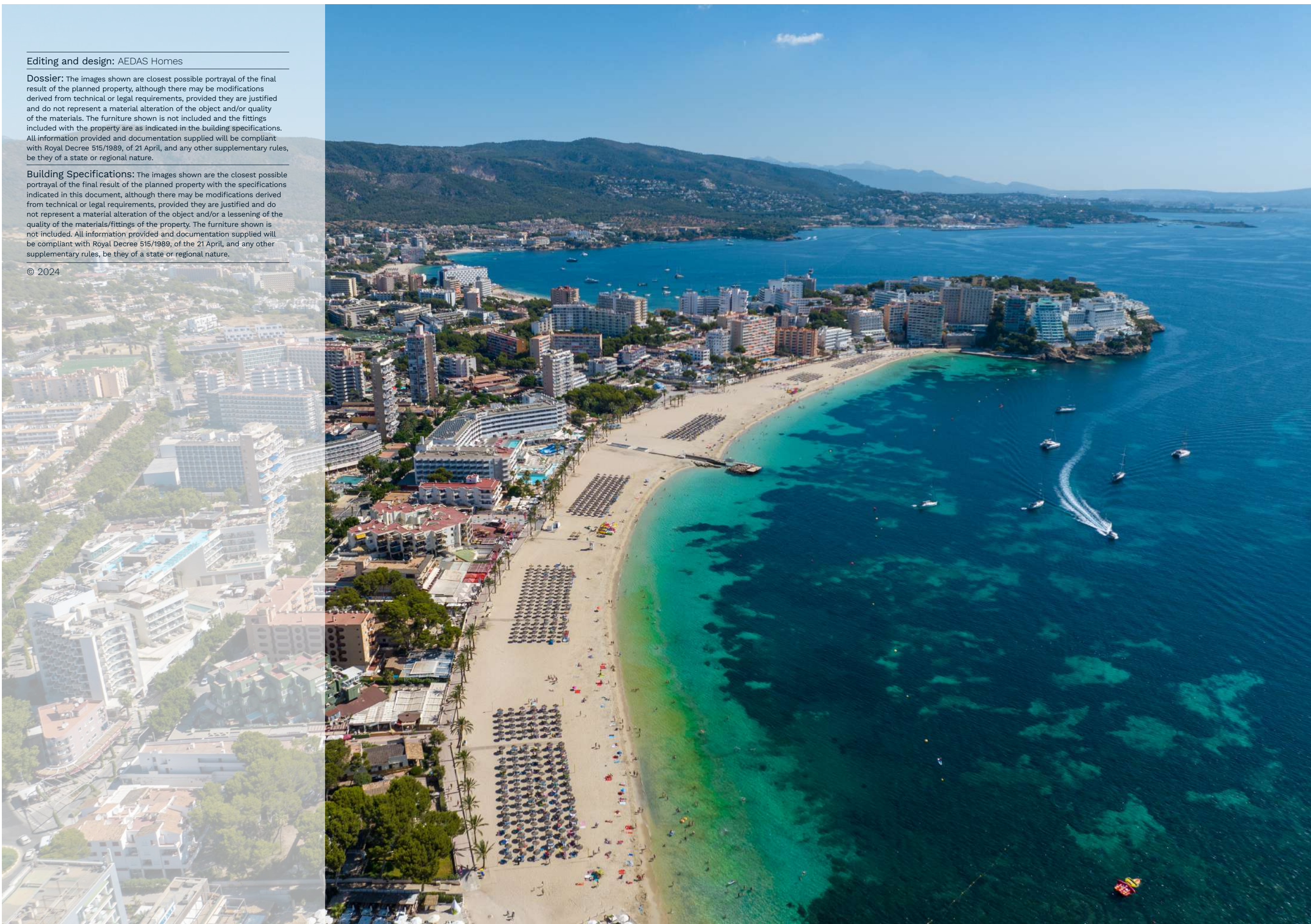

Nesea

Palmanova



Welcome

Our seal is a synonym of quality and trust and so we want your input to make your home a unique space that meets all your requirements. We are a new generation property developer offering you the talent and experience of a great team of professionals.

What do yo need?

Dossier

01 **Why Nesea in Palmanova?**

The home you are looking for

02 **Your new life, 400 meters from the beach**

Perfectly communicated
A short walk from everything you need

03 **Architecture d'auteur**

04 **Places to get away from it all**

05 **Warm, light-filled rooms**

Cosy, top-quality spaces
Adapt your home to your requirements

06 **Energy efficiency always in mind**

Building Specifications

01 **Inside your community**

The community interior
Entrances and lobbies

02 **Your home**

Hall, lounge room, passageway and bedrooms
Kitchen
Select Service
Bathrooms
Terraces and private gardens
Interior walling and insulation
Interior carpentry

03 **Installations**

Plumbing and drains
Heating/Climatization
Electricity/Telecommunications
Ventilation

04 **The building**

Façade and roofing
Exterior carpentry and glazing
Structure and foundations
Staircases and floor landings
Garages and boxrooms

05 **Sustainability measures**

Façades with ETICS
Swimming pool with saltwater chlorination system
Aerothermal Systems
Water savings

Gracias por tu confianza en nosotros



Dossier



01

Why Nesea in Palmanova?

AEDAS Homes has given this development located in Palmanova (Calvia), the name Nesea (Nesaea, in English) after one of the sea nymphs featured in Homer's Illiad. Also known as "islander", this name will always bind your home to the Mediterranean and its location in Majorca.

Now you can enjoy your home without having to give up the idea of being close to the sea and having the scent of the waves drifting in through your window.

**Your dreams have brought you this far.
Now take it to the next level.**



The home you are looking for

We know the home you are looking for is like you: It has your personality, that special way you look at life and a touch of singularity that makes it a space just for you. Hence, we, at AEDAS Homes, are offering you an exclusive residential complex comprising thirty-six 1-, 2- and 3-bedroom homes including groundfloor units with gardens and upperstorey flats with large terraces, all with garage and boxroom facilities, in a spot just a few minutes from Palma and its international airport. In Palmanova, you will enjoy the comfort brought by living in an area that has all the necessary services within easy reach.



O2





Your new life, 400 meters from the beach

Nesea is located in Palmanova, one of Calvia's beachside residential hubs. In just a few minutes, you can enjoy a relaxing dip in the sea or a pleasant stroll along the Mediterranean shoreline.





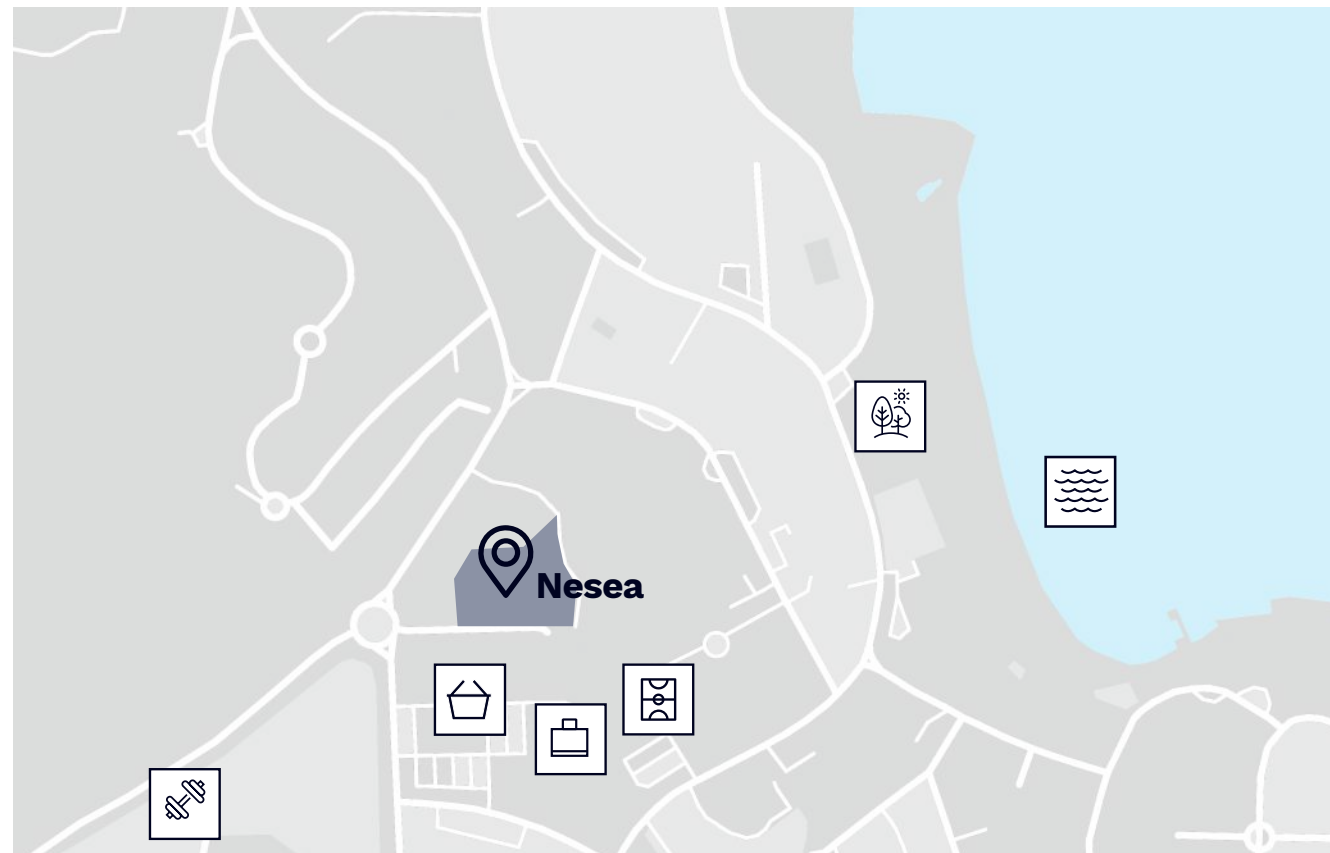

Furthermore, your new house forms part of a neighbourhood offering the convenience of living just 15 minutes from Palma city centre and 30 minutes from the airport.

Relax taking long walks along the beach, having a swim in the sea or enjoying the variety of different services, without forgoing superb communications.



-  Palma de Mallorca
-  Palma de Mallorca Airport
-  Beach
-  Golf
-  Yacht club



-  Son Maties Beach
-  Sports center
-  La Vila shopping center
-  Supermarket
-  Padel&Football Costa de Calvià Sports center
-  Park

Perfectly communicated

Your new home stands in a well communicated setting with all the usual services within easy reach. From your new home, you can quickly be at shopping malls, schools, sports centres and supermarkets, and commuting to Palma will be quick and comfortable along the Ma-1 access road.

If you prefer to leave your car in your parking bay, you can use the 104, 105, 123 and A11 inner city bus services which connect your neighbourhood with Palma city centre as well as other destinations.

A short walk from everything you need

You will find all the services you need in the area surrounding Nesea, hence it is the perfect location for those seeking a quiet life while enjoying all the big city comforts.

You will be able to practise a wide range of sporting activities close to your new home, such as those available at the Padel & Football Costa de Calvià sports complex or the Palmanova Sailing Club, and there are extensive tracks and paths allowing you to relish long hikes. If golf is your thing, the Santa Ponsa golf course will be the ideal place to put your best swing to the test.

Your neighbourhood will include shopping and leisure centres such as the Centro Comercial La Vila or Katmandú Park, supermarkets like Aldi and a wide variety of bars and restaurants.



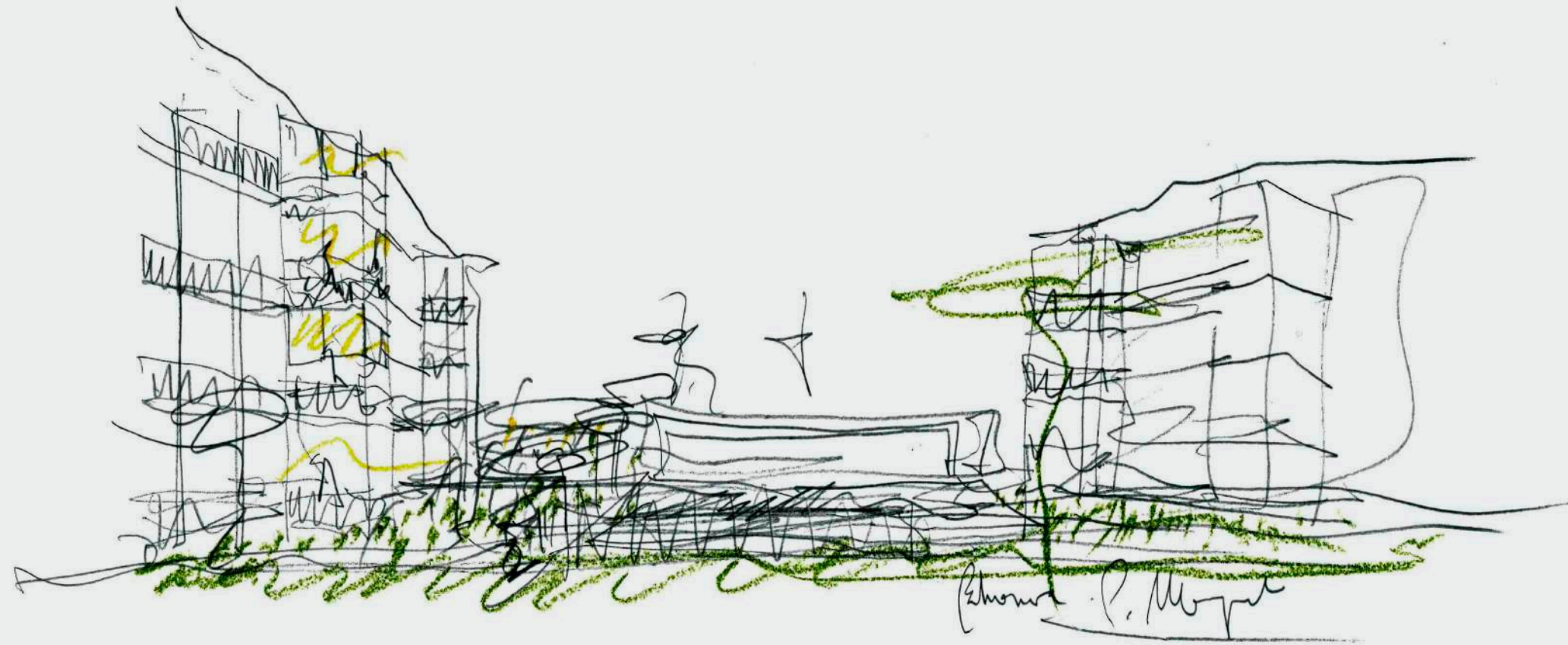

03

Architecture d'auteur

Nesea is a project signed by Mangado & Asociados architectural studio, which is responsible for some of the island's most emblematic undertakings such as the Palau de Congressos in Palma. This studio is one of the most prestigious firms in Spain, winner of numerous prizes both at home and abroad.

The architecture of your new home is taken care of down to the finest detail, to combine maximum functionality with the most exquisite design. Interior and exterior forge a 'dialogue' in which natural light and integration of the outdoor spaces into the main rooms in your home are major features.

Who said beauty was only in the interior?



"A spot between the interior and the exterior.

A spot that seeks the value of architecture in the fact of being able to live comfortably in those intermediate spaces which we can find in few places like in Palma de Mallorca, on the Mediterranean. Intermediate spaces between light and shade which are never the same and which offer us the marvelment which should never be forgone in good architecture.

That is the architecture we have striven to accomplish in this case"

Francisco Mangado



04

Places to get away from it all

One of AEDAS Homes' fundamental premises is to look after its customers, therefore we aim to make your everyday life easier. Your new community is projected to include comprehensive communal areas where you can shake off your stress and get away from it all.

Nesea will give you the perfect place to truly unwind. The community comes with a pool for adults and children, a community hall for holding parties and events with your friends and family and fully equipped gymnasium to help you keep fit without having to leave home. Take a relaxing stroll through your landscaped community gardens and enjoy the essence of the Mediterranean air in the different outdoor spaces your new home has to offer.

The community pool will be fully integrated into outdoor garden areas, creating a unique and distinct kind of space that will become one of the spots particularly special to you in the complex. Have a relaxing swim or invite family or friends to cool off on summer afternoons and share some unforgettable moments.





05

Warm, light-filled rooms

The dwellings open out into the outdoors through large windowpanes, creating great luminosity and a unique ambience.

Furthermore, to enable you to enjoy the island's superb climate, the lounge in your home merges with the exterior through a generous terrace which will undoubtedly become one of your favourite spots in your new home. Any time of day, a birthday party, an anniversary celebration can become the best plan for enjoyment out of doors.

Cosy, top-quality spaces

Because we know you like to get home and enjoy it, all the rooms in your dwelling are designed so that you feel enveloped in their comfort, surrounded by high-end specifications.

Nesea comes with unsurpassable finishes and materials; while you sleep in your bedroom or cook your favourite dishes, you will soak up the comfort and harmony between the different spaces.

Nesea offers the perfect blend of modernity, quality and comfort. The homes are projected with the best building specifications, the highest levels of comfort and the most avantgarde energy performance to meet the demands of today.

All the dwellings come with:

- › A spacious lounge-dining room.
- › A fully furnished and fitted kitchen.
- › 2 full bathrooms (one en suite).
- › 1, 2 or 3 bedrooms, depending on the unit type.
- › Master bedroom with walk-in closet.
- › Spacious terrace of up to 18 m2.
- › Ground floor units with private gardens.





Adapt your home to your requirements

AEDAS Homes dwellings are conceived to adapt to your present and future needs, fulfilling your preferences as regards space. To this end, Nesea offers you two different ground-floor layouts.

You can choose between:

- › Lounge-dining room separate from the kitchen.
- › Open kitchen integrated into the lounge.

Your home matches your lifestyle. Take a look and find the plans which best match your tastes and preferences and choose the one that will be your future home.





06

Energy efficiency always in mind

AEDAS Homes is committed to the future through sustainable buildings, both at their start up and in their final stage. All our homes offer you high energy performance ratings so that at the same time as you are contributing to looking after the environment, you also benefit from the advantages of doing so.

Given that your home is efficient, you will notice that your bills are lighter at the end of the month. The type of glazing used in the project helps to keep a constant temperature thus implying spending on climatization is substantially lower. At the same time, in addition to your thermal comfort, you will notice that noise is completely insulated so you can rest without anything disturbing your sleep.

All these improvements in efficiency help to lower CO2 emissions, so that every day, effortlessly and without realising it, you will be helping to take care of our planet.



 **Lighting**

Large windowpanes to maximise the entry of natural light.

 **Thermal quality**

Insulation adapted to climate requirements.

 **User Manual**

Guidance on how to use the building efficiently.

 **Innovation**

New strategies to maximise the benefits for the environment.

 **Renewable energies**

Domestic hot water produced using aerothermal technology. Conduit climatization.

 **Sustainable transport**

Pre-installation for electrical vehicle charging station.

 **Noise insulation**

With the exterior and between dwellings.



Building Specifications

01

Inside your community



At AEDAS Homes, quality is our hallmark and an ever-present objective, hence we have put great thought into all the details of your new home.









The community interior

Your community will make you feel proud of your new home even before you go inside.

To help you share unforgettable moments with those you love the most, the development will come with a spacious outdoor area which will include a saltwater community pool for children and adults to enjoy together, a social hall with a fully equipped gymnasium and an area for parking bicycles.

- › Saltwater chlorinated swimming pool.
- › Landscaped gardens.
- › Social hall.
- › Fully equipped gymnasium.
- › Bicycle parking facilities.
- › Accessibility ramps.



-  Saltwater chlorinated swimming pool for adults.
-  Saltwater chlorinated swimming pool for children.
-  Solarium area.
-  Fully equipped gymnasium.
-  Bicycle parking facilities.
-  Social hall.
-  Accessibility ramps.
-  Landscaped gardens.

Entrances and lobbies

At Nesea, the utmost attention has been paid to the community areas. Both the floors and walls of the indoor spaces will combine different top-quality materials depending on the zone.

They will also include technology in the form of lighting triggered by separate motion sensors for the different zones and floors, thus rationalising resource use and consumption which will translate into important energy savings at the end of the month.

The cars of the elevators, which run from the garage to the dwellings, will be finished in accordance with the rest of the project and be sized to meet Accessibility Regulations. They will have automatic doors and be fitted with an alarm and a telephone service for emergencies.

02

Your home



Hall, lounge room, passageway and bedrooms

Your new home will be paved in porcelain stoneware. The floors in all the rooms will be finished with a white skirting board to match the interior carpentry, thus creating a fully integrated ambience throughout the entire dwelling.

The walls will be finished in plain emulsion paint. The hall and passageway will come with suspended plasterboard ceilings, also in an emulsion paint finish.

Kitchen

Preparing your favourite dishes will be much easier in this space we have designed for you. These are the specifications and finishes included in your new kitchen in Nesea:

- › Porcelain stoneware flooring as in the rest of the dwelling, finished with a white skirting board.
- › Walls finished in plain emulsion paint.
- › Suspended plasterboard ceiling in a plain emulsion paint finish.

Your kitchen in Nesea will be delivered with highcapacity wall and base units in a contemporary design and it will also include the following fittings and appliances:

- › Induction hob.
- › Filter hood.
- › Electrical oven and microwave.
- › Compact quartz worktop and backsplash.
- › 2 built-in recycling bins.
- › Sink with mono mixer water saver tap.





Select Service

The AEDAS Homes Select Service enables you to customise certain aspects of your new home:

- › Choose between different ambiances depending on your tastes.
- › Adapt the kitchen and lounge spaces in your new home to best meet your needs.
- › Improve your comfort with security devices and technology.
- › Choose from among a variety of packs and improve the specifications, the equipment and the level of comfort in your home.
- › Make your new home even more sustainable.

Select

Bathrooms

The walls of both the master and secondary bathrooms will be lined in ceramic tiling combined with porcelain stoneware floors to thus withstand the damp and retain the properties of these surfaces intact.

They will come with continuous, damp-proof suspended ceilings in a plain emulsion paint finish. For your total convenience, the heating/

climatization system will have an access hatch in the suspended ceiling below its location enabling easy future maintenance of the interior unit.

All the bathrooms will be fitted with mono mixer tapware on the washbasins and thermostatic taps in the master bathroom shower and on the bathtub in the secondary

bathroom, and come with white sanitary appliances in a modern design. Both bathrooms will be fitted with a wall hung vanity and washbasin, a mirror and LED luminaries. The master bathroom will come with a shower screen and a wall hung toilet with a concealed cistern.



Terraces and private gardens

The ground floor terraces will have a water tap, lighting point, power socket and TV Jack.

The terraces on the other floors will include a lighting point and power socket.

Furthermore, to ensure your utmost safety, the open-air flooring connected to the lounge will be paved in non-slip porcelain stoneware especially for exteriors.



Interior walling and insulation

The drywalling employed in your new home will prove most convenient because it will avoid wiring chases and eliminate sound bridges because the installations will be conducted inside the wall cavity.

Furthermore, it will provide the perfect base for a plain paint finish.

- › **Dividing walls between rooms:** In drywalling.
- › **Dividing walls between dwellings:** In dry/mixed walling insulated to Technical Building Code standard.
- › **Dividing walls between dwellings and communal spaces:** In dry/ mixed walling and insulation.

Interior carpentry

AEDAS Homes has also paid great attention to the interior carpentry so you can enjoy all the details in your new home.

- › The home entrance door will be armoured, and it will come with a white lacquered finish on the inside and an exterior finish integrated into the façade ensemble. It will also be fitted with a spyhole.
- › Doors inside the dwelling will be finished in white lacquer with stylish handles, giving your home a smart, contemporary appearance. In general, they will be swing opening, except in exceptional cases where sliding doors may be fitted for questions of functionality.
- › The built-in wardrobes will be Monoblock type. They will generally have swing-opening doors; in exceptional cases sliding doors will be fitted, exclusively following functionality criteria. They will come in a white lacquer finish to match the rest of the carpentry and modular interiors with a melamine lining, including an upper shelf and hanging rail.



03

Installations



Plumbing and drains

The plumbing installation will include water inlets for each bathroom and kitchen fitting (sink) and for the electrical appliances in the kitchen (dishwasher) and utility area (washing machine). Your home will have a general cut-off valve and individual cut-off valves for each room containing plumbing. Domestic hot water for your home will be produced by a high energy efficiency aerothermal unit.

Each of the bathroom fittings in the home will be connected to the drains using PVC downpipes which will pass through the conduit chambers beside the dwelling.

Heating/Climatization

To ensure you enjoy the utmost comfort, your new home will be fitted with a highly efficient system comprising aerothermal units to produce domestic hot water and conduit air conditioning, with temperature controlled by thermostats which divide the home into two sectors (day- and night-time usage).

For your convenience, the climatization system will have an access hatch in the suspended ceiling below its location enabling easy future maintenance of the interior unit.

Electricity/ Telecommunications

Your home at Nesea will come with the electricity and telecommunications sockets required to meet regulatory standards, as well as a video door phone for communication with the lobbies and the entrance gate to the community. You will also have data, telephone and TV jacks in the lounge, kitchen and bathrooms.

The interior lighting in the hall, vestibule, bathrooms and kitchen will come from recessed LED luminaries. The other spaces will have lighting compliant with the Low Voltage Electrotechnical Regulations.

Ventilation

Your home will include a ventilation system to assure the indoor air is healthy and compliant with the Technical Building Code. Nesea also includes, as an optional extra, the possibility of installing a smart dual-flow ventilation system with an individual heat recovery unit. This system provides significant energy savings.

04

The building

Façade and roofing

To ensure you also enjoy your new home even before you go inside, the façades have been designed using state-of-the-art materials with an external thermal insulating composite system (ETICS), that will give it a sleek, modern look. The decorative finishes will combine thermal performance with the most avant-garde design, adapted to meet the needs of the 21st century.

The façade will also be lined in its interior, producing an enclosure which is thermally- and sound-insulated throughout; and this will produce important energy savings and make the interior of your home much more comfortable.

The roofs have been designed depending on the use for which they are to be employed, always guaranteeing their watertightness using waterproofing systems



Exterior carpentry and glazing

All the exterior carpentry and glazing will be compliant with the Technical Building Code and, more specifically, the Basic Energy Saving and Noise Protection Documents, thus raising the level of comfort inside the dwelling. Nesea will come with:

- › Aluminium profile carpentry with thermal bridge break combining different opening systems depending on location.
- › Double-glazing with a dehydrated air chamber.
- › Manual, roll-up, fixed slat blinds in bedrooms; colour similar to exterior carpentry.

Structure and foundations

The structure of your new home will largely be built in reinforced concrete compliant with current Earthquakeresistant Construction Regulations.

The entire structure will be calculated to Technical Building Code standard. The foundations will be projected per the conclusions of the Geotechnical Survey.

Staircases and floor landings

At Nesea, we have addressed every detail in the communal areas. Both the floors and the walls of the indoor spaces will combine different materials depending on the zone.



Exterior carpentry

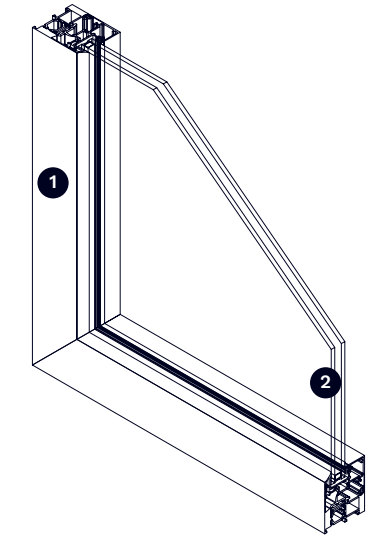

- 1 Aluminium carpentry with thermal bridge break
- 2 Double-glazing with air chamber

Garages and boxrooms

Garage entry and exit doors will be automatic and fitted with a crush-prevention safety device. They will be operated by remote control.

The boxrooms will be painted and come with a metal door.

05

Sustainability measures

Façades with ETICS

Your development in Nesea will include ETICS in its façades. These initials stand for External Thermal Insulating Composite System, which ensures that your home is protected against extreme weather conditions. It will thus maintain a constant temperature that will not be altered whether it is hot or cold outside. The thermal insulation will mean your energy consumption for climatization (heating or air conditioning) will be much lower.

Façades with ETICS

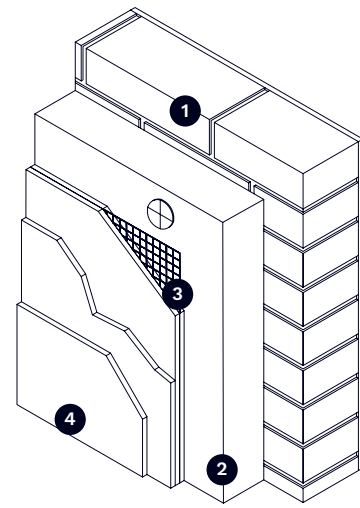

- 1 Façade
- 2 Thermal insulation
- 3 Reinforcement mesh
- 4 Claddings

Swimming pool with saltwater chlorination system

Thinking of your wellbeing, the swimming pool at your new home in Nesea will be fitted with a saltwater chlorination system. This water treatment process does not use

chemical chlorine therefore it does not cause allergic reactions, skin rashes or eye problems. Furthermore, it does not generate waste, thus helping look after the planet.



Aerothermal Systems

An aerothermal unit is an efficient heat pump system that takes advantage of the renewable energy in the air to heat/cool your home and obtain domestic hot water. A heat pump (known as the outdoor unit) extracts the energy present in the air, sending it to the indoor unit which warms water for heating the dwelling and providing domestic hot water.

In summer, it works the opposite way around; heat from your home is sent outside to produce air conditioning.

In addition to the environmental benefits, the energy performance of this system translates into significant savings in your electricity bills.

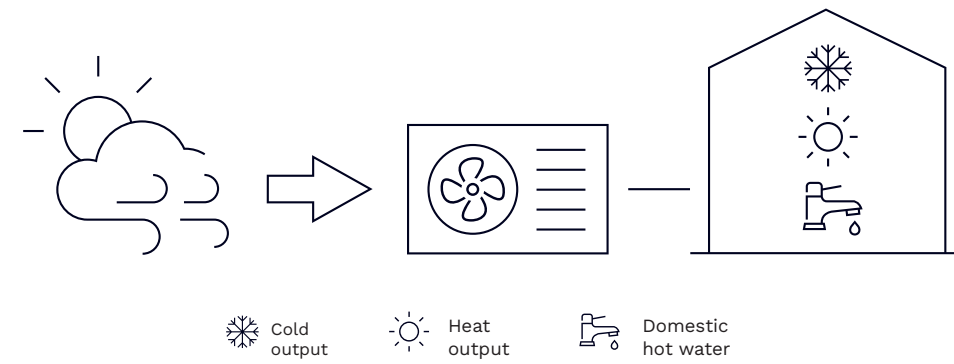

Water savings

At AEDAS Homes, we endeavour to use the planet's resources responsibly. At Nesea, therefore, we have implemented different water-saving measures which not only contribute to protecting the environment but also mean your bills are lighter at the end of the month. Such measures include water-saver tapware and dual-flush toilets.

Check out all the sustainability measures Nesea includes in your Ecoliving document.



Thank you for placing your trust in us

With you from the very first. At AEDAS Homes, our professionals deeply share our company's values and they attend your home as if it were their own. Professionalism, innovation, design and sustainability are the cornerstones of the service you receive when you choose us. Our highly qualified team has vast training and experience in the world of residential developments and with their friendly approach and involvement they will make you feel at home even before you move in.

When you choose an AEDAS Homes dwelling, not only are you opting for top quality specifications and avant-garde architecture, you are also committing to looking after the environment. Environmental protection is one of our great proposals, and in all our projects our commitment to rational use of natural resources and the employment of efficient systems resulting in energy savings are both quite evident.

At AEDAS Homes we know that sustainability and design are not at odds with each other and hence we have achieved "green" homes that include state-of-the-art innovation in their interior. We apply avant-garde technology to make your life much more comfortable and in tune with 21st-century requirements.



Development address:

Calle Cabo Juan García, 4 y 6
Calviá

Sales office in Palma:

Centro comercial La Villa, local 3.2
Calle Carlos Sáenz de Tejada, 8,
Calviá

T. +34 871 890 010

aedashomes.com

